

# 7.1.4 Vertex 1 or 2 with AVR



**CONFIGURATION EXAMPLE ONLY  
PLEASE CONTACT CAVD FOR A DETAILED  
CUSTOM DRAWING FOR YOUR PROJECT**

### Applying the Congard Code

- 1) Do not use bass management features in the AVR/Processor; every output should be set as Large/Full Range
- 2) Set your individual speaker levels to reference or as you prefer
- 3) Run all front wall speakers, subs and heights without individual delay, i.e. at 0ms
- 4) Run all surround speakers with equal individual delay settings. Calculate this based on the longest distance from a seat to a surround speaker converted to milliseconds. Then add 5ms and apply this to all surrounds.
- 5) Set the Global Delay on your AVR/Processor for perfect Lip-Sync to the display device.

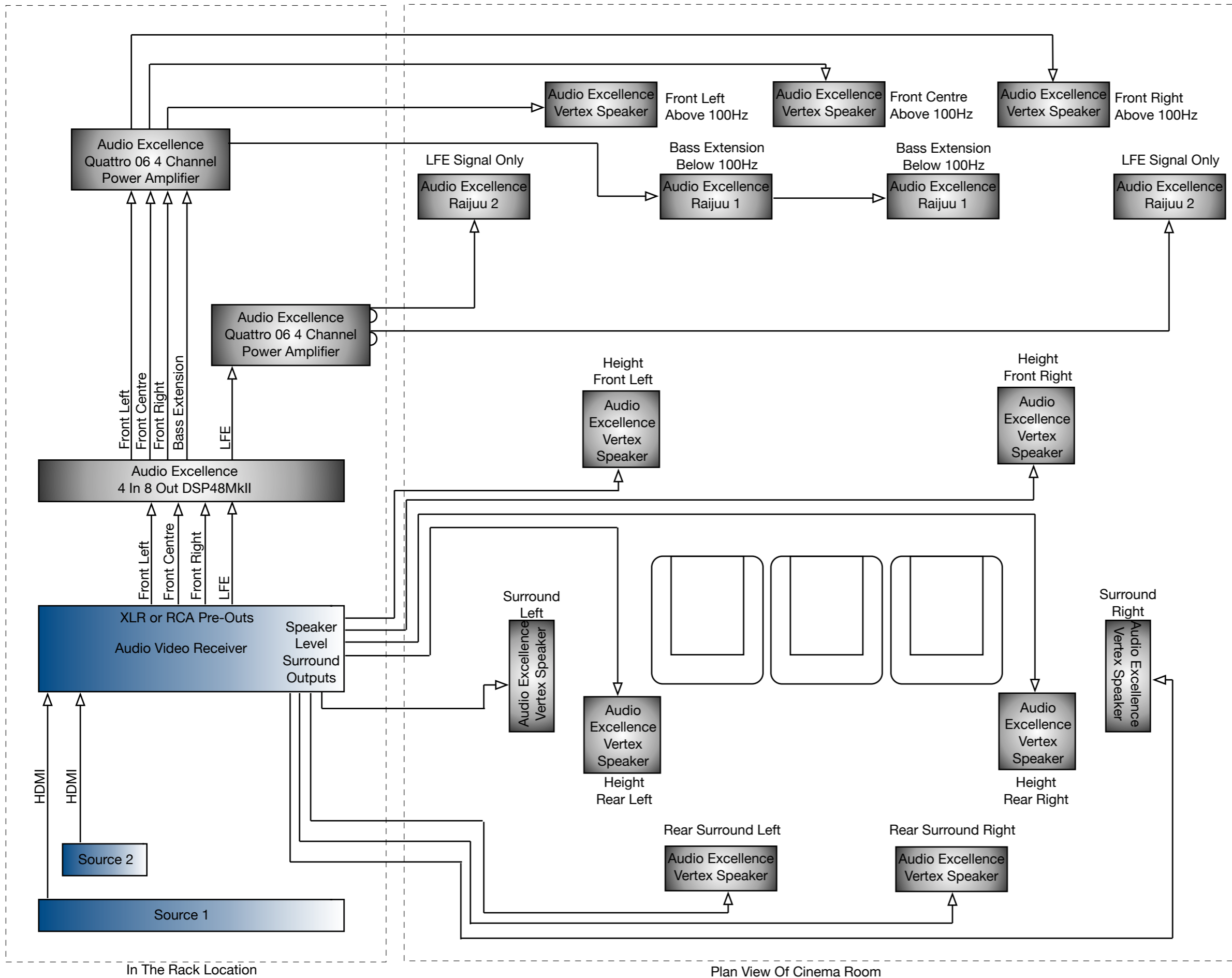

In The Rack Location

Plan View Of Cinema Room